

Hardware Manual

Industrial Cellular Router

ICR-2701

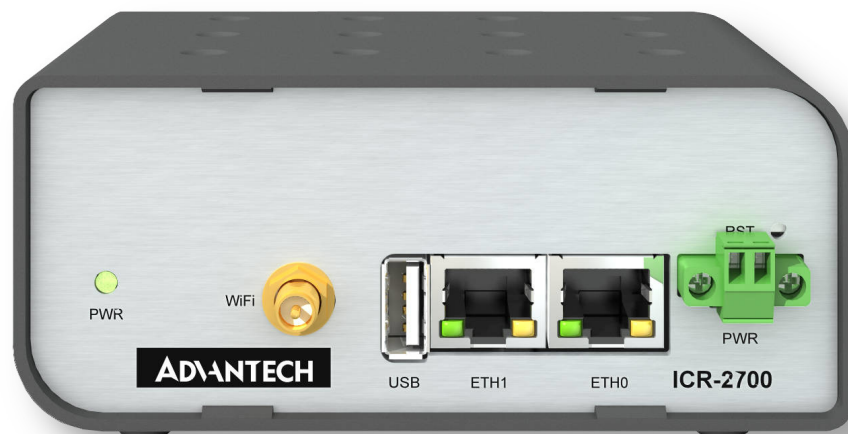
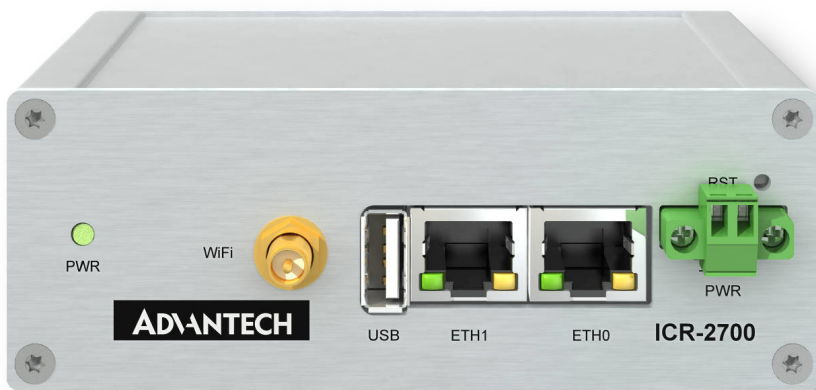

© 2025 Advantech Czech s.r.o. No part of this publication may be reproduced or transmitted in any form or by any means, electronic or mechanical, including photography, recording, or any information storage and retrieval system without written consent. Information in this manual is subject to change without notice, and it does not represent a commitment on the part of Advantech.

Advantech Czech s.r.o. shall not be liable for incidental or consequential damages resulting from the furnishing, performance, or use of this manual.

All brand names used in this manual are the registered trademarks of their respective owners. The use of trademarks or other designations in this publication is for reference purposes only and does not constitute an endorsement by the trademark holder.

Used symbols



Danger – Information regarding user safety or potential damage to the router.



Attention – Problems that can arise in specific situations.



Information – Useful tips or information of special interest.



Contents

1. Product Overview	1
1.1 Document Content	1
1.2 Product Introduction	2
1.3 Hardware Overview	3
1.4 Order Codes	4
1.5 Product Revisions	5
1.6 Package Contents and Accessories	6
1.7 Product Dimensions	8
1.8 Mounting Recommendations	10
1.9 DIN Rail Mounting	11
1.10 Product Label	12
1.11 First Use	13
2. Hardware Functionality	14
2.1 Antennas	14
2.2 Ethernet Interfaces	14
2.3 Power Supply	15
2.4 Low Power Mode	16
2.5 USB Port	16
2.6 LED Status Indication	17
2.7 Reset Functions	18
3. Technical Specifications	19
3.1 Basic Parameters	19
3.2 Standards and Regulations	20
3.3 Type Tests and Environmental Conditions	21
3.4 Parameters of WiFi	22
3.5 System Configuration	23
Appendix A: Troubleshooting	24
Appendix B: Customer Support	26
Appendix C: Regulatory & Safety Information	27
Appendix D: Related Documents	28

List of Figures

1	Hardware Overview of the Router	3
2	Metal Box – Top, Side and Front View	8
3	Plastic Box – Top, Side and Front View	9
4	Position of the DIN Rail Clip	11
5	Removing Router from the DIN Rail	11
6	Product Label	12
7	Ethernet Connector Pinout	14
8	Connection of Power Supply	15
9	Position of the Grounding Screw	15
10	USB Connector Pinout	16
11	Resetting the Router	18

List of Tables

1	Hardware Overview of the Router	3
2	Order Codes Overview	4
3	HW Revisions History	5
4	Contents of Package	7
5	Ethernet Connector Pinout Description	14
6	Power Supply Pinout	15
7	USB Connector Pinout	16
8	LED Status Indication	17
9	Basic Parameters	19
10	Standards and Regulations	20
11	Type Tests and Environmental Conditions	21
12	Technical Parameters of WiFi	22
13	System Configuration	23

1. Product Overview

1.1 Document Content

This manual provides detailed information for Advantech ICR-2701 routers, offering comprehensive guidance on the following topics:

- **Product Overview** – Product-related information such as order codes, product revisions, package contents, product dimensions, and mounting instructions.
- **Hardware Functionality** – Description of all hardware components, including SIM slots, antennas, Ethernet ports, power options, LED status indicators, reset functions, and others.
- **First Use** – Instructions for the initial setup and usage of the router.
- **Technical Specifications** – Basic parameters, standards and regulations, type tests, module specifications, and interface parameters.

1.2 Product Introduction

Industrial router ICR-2701 is **LAN Router & Edge Computing Gateway** focused on the global market.

The router, which may have a **metal** or **plastic** box, is equipped with two independently configurable **Ethernet ports**, with one **USB 2.0** host interface and with **LEDs for status** indication. The router can be equipped with a **dual-band WiFi module**, but this must be part of the initial configuration – it cannot be assembled to the router at some point in the future.

The router supports the **Low Power Mode** and **hardware watchdog**, which monitors the router status and performs an automatic restart if required.

The router supports **VPN tunnel** creation using various protocols to ensure safe communications. The router provides diagnostic functions which include automatic monitoring of the wireless and wired connections, automatic restart in case of connection losses, and a hardware watchdog that monitors the router status.

With open Linux platform and wide possibilities of programming customer SW applications in **Python**, **C/C++**. The Advantech existing app library **Router Apps** (formerly *User modules*) with apps already developed to enhance specific router functionality including industrial protocol conversions and support of IoT platforms such as **MS Azure**, **Cumulocity**, **ThingWorx**, and others are supported on the router.

The router supports automatic upgrades of both its configuration and firmware, leveraging updates from a central server. This feature ensures that the router remains up-to-date with the latest enhancements and security protocols.

This model is compatible with Advantech's remote device management platforms: [WebAccess/DMP](#) and [WebAccess/VPN](#). These platforms facilitate comprehensive management and monitoring of network devices.

Examples of possible applications

- mobile office
- security system
- remote monitoring
- vending and dispatcher machines

1.3 Hardware Overview

The router case preview is shown in Figure 1. A short description of hardware parts of the router is listed in Table 1, including the links to the chapters with a detailed description. For a router in a plastic box, the description of the components is similar.



Figure 1: Hardware Overview of the Router

#	Item/Caption	Type	Description
1	LED	-	Status LED indication; see Chapter 2.6.
2	WiFi	RP-SMA female	WiFi antenna connector; see Chapter 2.1 for more information and Chapter 3.4 for WiFi parameters.
3	USB	USB-A	USB-A type socket connector; see Chapter 2.5.
4	ETH0, ETH1	RJ45	100 MB Ethernet connection for the first and second LAN; see Chapter 2.2.
5	PWR	2-pin terminal	Power supply socket; see Chapter 2.3.
6	RST	-	Button to reboot the router or to restore the default configuration; see Chapter 2.7.
7	DIN clip	-	DIN rail clip, included as standard accessories; see Chapter 1.9.
8	Grounding screw	M3	Pay attention to proper grounding of model with metal box; see Chapter 2.3.

Table 1: Hardware Overview of the Router

1.4 Order Codes

Order codes overview is shown in the table below.

Order code	Configuration
ICR-2701	metal box, ETH0, ETH1, USB
ICR-2701P	plastic box , ETH0, ETH1, USB
ICR-2701A01	metal box, ETH0, ETH1, USB, accessories with Ethernet cable, two cellular antennas, and EU power supply
ICR-2701PA01	plastic box , ETH0, ETH1, USB, accessories with Ethernet cable, two cellular antennas, and EU power supply
ICR-2701A02	metal box, ETH0, ETH1, USB, accessories with Ethernet cable, two cellular antennas, and UK power supply
ICR-2701PA02	plastic box , ETH0, ETH1, USB, accessories with Ethernet cable, two cellular antennas, and UK power supply
ICR-2701W	metal box, ETH0, ETH1, USB, dual-band WiFi
ICR-2701WP	plastic box , ETH0, ETH1, USB, dual-band WiFi
ICR-2701WA01	metal box, ETH0, ETH1, USB, dual-band WiFi , accessories with Ethernet cable, two cellular with one WiFi antennas, and EU power supply
ICR-2701WPA01	plastic box , ETH0, ETH1, USB, dual-band WiFi , accessories with Ethernet cable, two cellular with one WiFi antennas, and EU power supply
ICR-2701WA02	metal box, ETH0, ETH1, USB, dual-band WiFi , accessories with Ethernet cable, two cellular with one WiFi antennas, and UK power supply
ICR-2701WPA02	plastic box , ETH0, ETH1, USB, dual-band WiFi , accessories with Ethernet cable, two cellular with one WiFi antennas, and UK power supply
ICR-.....-S1..	The -S1 prefix indicates that the product is designed for the S1 Products platform. This platform ensures compliance with strict security requirements. For more details, refer to the S1 version of the configuration manual [1] .

Table 2: Order Codes Overview

1.5 Product Revisions

For the product revision history of the entire product platform, refer to the table below. Please note that some revisions may not be available for certain order codes. The revision number is printed on both the packaging and product labels.

The router GUI can also display the product revision under *Status* → *General* → *System Information* → *Product Revision*. Please note that the default revision (Rev. 1.0) may not be available here.

Rev.#	Description
1.0	Initial version (revision number not printed on the labels).
2.0	WiFi support added to the mainboard; see PCN-2023-10 for details.
2.1	Not released for this model.

Table 3: HW Revisions History

1.6 Package Contents and Accessories

Table 4 refers to router package contents and other accessories, which depend on the order code; see Chapter 1.4. You can order an accessory separately; use the order code mentioned.

Description	Figure	Q'ty
Router in metal or plastic box		1 pc
DIN rail clip with screws (screws differ for metal and plastic versions)		1 set
2-pin terminal block for power supply (deployed on the router)		1 pc
Printed <i>Quick Start Guide Leaflet</i>		1 pc
Ethernet cross cable of length 1.5 m. Order code: <i>BB-KD-ETH</i>		0 / 1 pc
WiFi Antenna (RP-SMA male). Order code: <i>BB-AW-A2458G-FSRPK</i>		0 / 1 pc
Wall mount power supply, 12V/1A with EU plug. Order code: <i>BB-RPS-v2-EU</i>		0 / 1 pc

Continued on the next page

Continued from previous page



Description	Figure	Q'ty
Wall mount power supply, 12V/1A with UK plug. Order code: <i>BB-RPS-v2-UK</i>		0 / 1 pc
Wall mount power supply, 12V/1A with US plug. Order code: <i>BB-RPS-v2-US</i>		0 / 1 pc

Table 4: Contents of Package

1.7 Product Dimensions

For the dimensions of the product in metal and plastic boxes see the figures below. Note that all sizes are measured in millimeters.

Variant with Metal Box

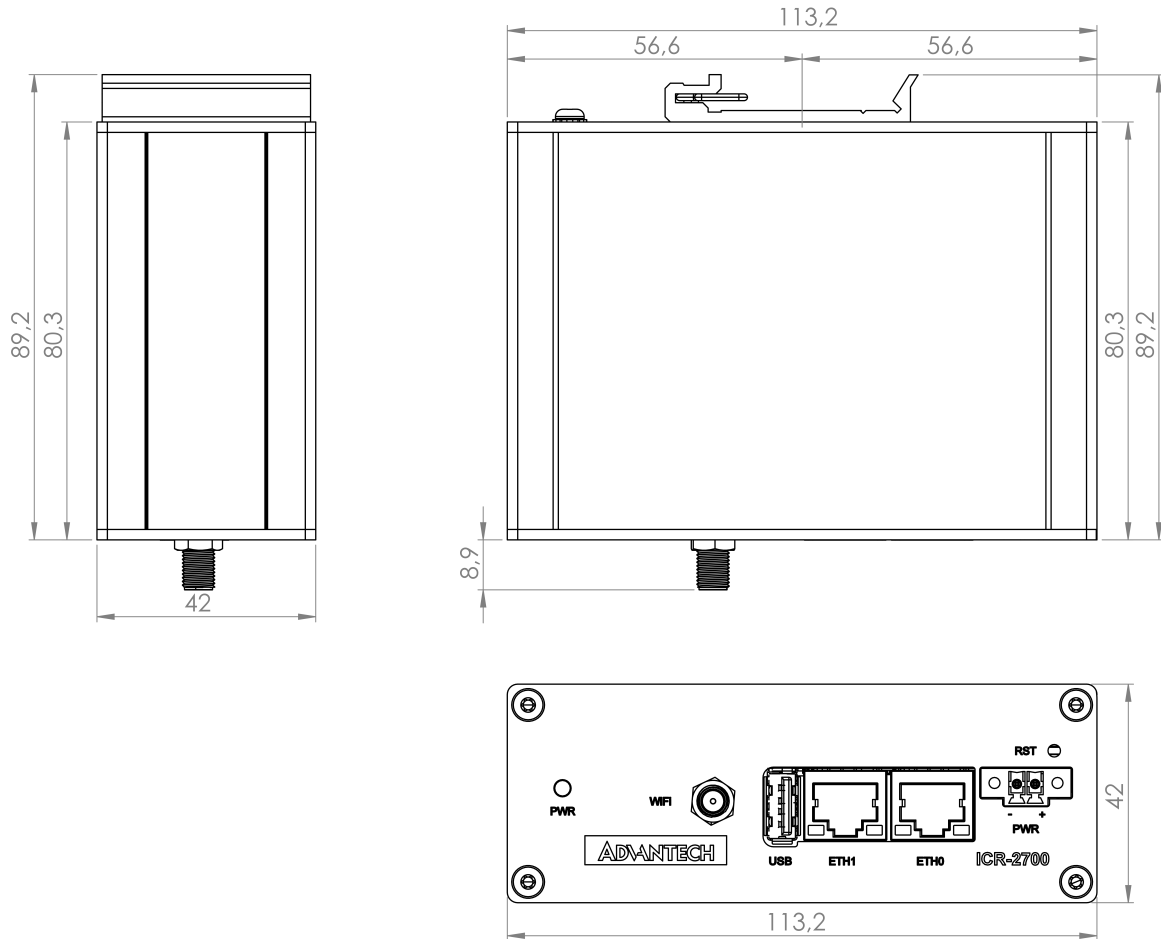

Figure 2: Metal Box – Top, Side and Front View

Variant with Plastic Box

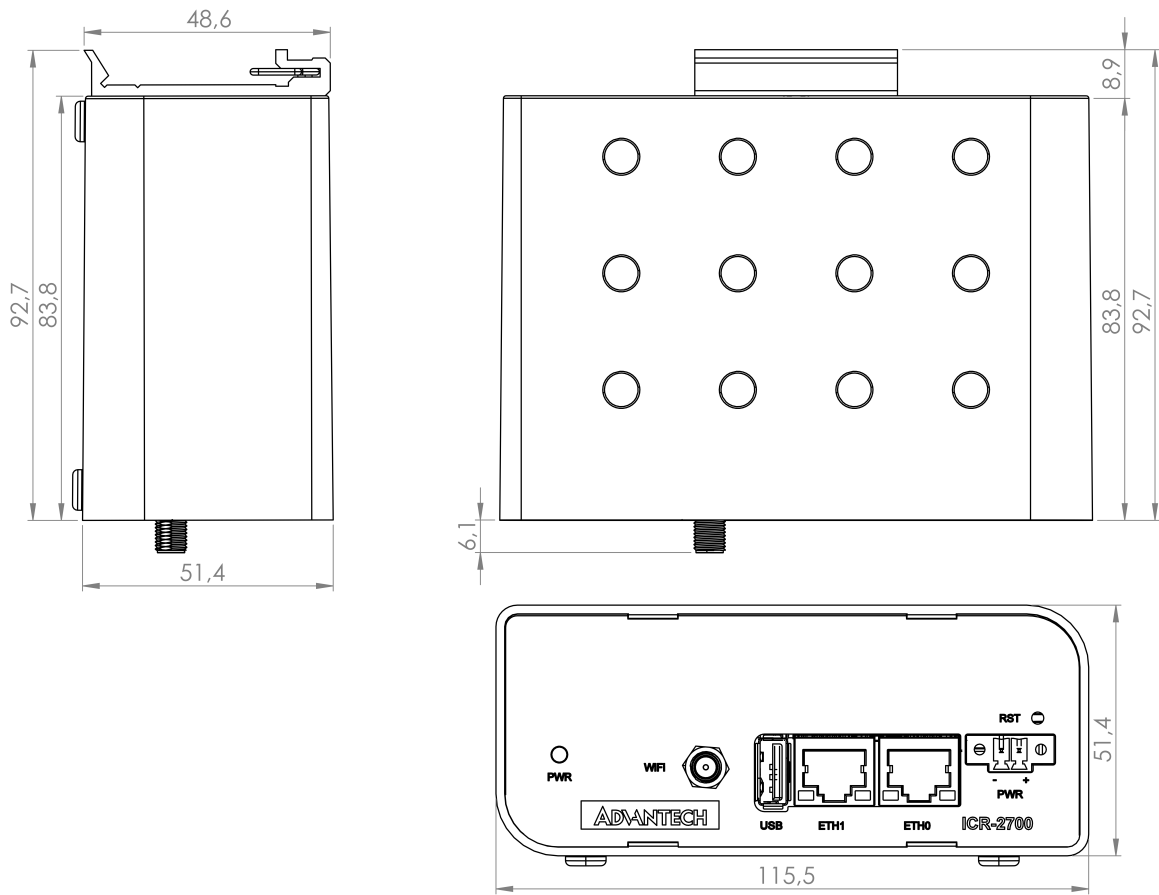

Figure 3: Plastic Box – Top, Side and Front View

1.8 Mounting Recommendations

The router can be placed:

- on a flat surface,
- on a DIN rail EN 60715 with the metal DIN rail clip (see Chapter 1.9)

For most applications with a built-in router within a switchboard, it is possible to recognize two kinds of environments:

- A non-public, industry environment of low voltage with high interference,
- a public environment of low voltage and without high interference.

For both of these environments, it is possible to mount the router to a switchboard, after which there is no need to have examination immunity or issues in connection with EMC according to EN 61439-1:2011.



In compliance with the EN 61439-1:2011 specification, it is necessary to observe the following assembly instructions for a router attached to a switchboard:

- For whip antennas it is recommended to observe a minimum distance of 6 cm from cables and metal surfaces on every side in order to avoid interference. When using an external antenna separate from the switchboard it is necessary to fit a lightning conductor.
- When mounting a router on sheet-steel we recommend using a cable antenna.
- For all cables, we recommend to bind the bunch, and for this we recommend:
 - The length of the bunch (the combination of power supply and data cables) should be a maximum 1.5 m. If the length of data cables exceeds 1.5 m or if the cable is leading towards the switchboard, we recommend installing surge protectors.
 - Data cables must not have a reticular tension of ~ 230 V/50 Hz or ~ 120 V/60 Hz.
- Sufficient space must be left between each connector for the handling of cables,
- To ensure the correct functioning of the router we recommend the use of an earth-bonding distribution frame for the grounding of the grounding screw, see Chapter 2.3.

1.9 DIN Rail Mounting

The DIN rail clip is suitable for a DIN rail according to EN 60715 standard only. There are four possible positions of the clip as shown in Figure 4.

i The DIN rail clip is the same for the metal and plastic router box. It just differs by the screws used.

! When mounting the DIN rail clip, tighten the screws with max. torque of 0.4 Nm.

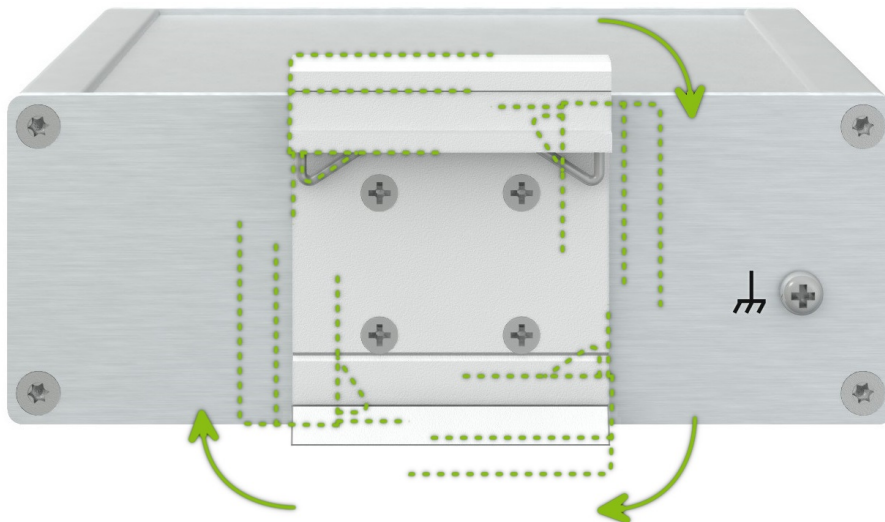

Figure 4: Position of the DIN Rail Clip

To remove the router from the DIN rail it is necessary to lightly push down the router so that the bottom part of the DIN rail clip hitched to the DIN rail get out of this rail and then fold out the bottom part of the router away from the DIN rail, see Figure 5.

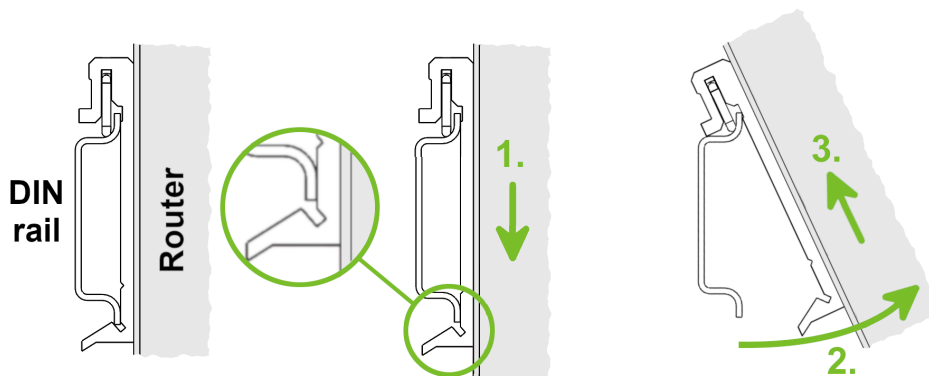

Figure 5: Removing Router from the DIN Rail

1.10 Product Label

The figure below shows an example of the product labels with all the information printed on them.



Figure 6: Product Label

1.11 First Use

You can perform the initial configuration of the router using a web browser on your PC. This interface enables router monitoring, configuration, and administration.

- 
- Before putting the router into operation, ensure that all components required for running your applications are connected. Refer to Chapter [1.3 Hardware Overview](#) for an overview of the hardware.

The procedure for connecting to a new router is described in the *Configuration Manual* [1], Chapter *Introduction* → *Configuration Environments* → *Initial Web Configuration GUI Access*. This manual also provides detailed descriptions and examples of router configuration using the web interface.

2. Hardware Functionality

See Chapter 1.3 for an overview of the product's hardware, along with links to chapters offering detailed explanations.

2.1 Antennas

If the router is WiFi equipped, connect the WiFi antenna to the WiFi RP-SMA female connector on the front panel.

i Recommended tightening moment for screwing the WiFi antennas to the SMA female connectors is 0.9 Nm.

2.2 Ethernet Interfaces

The panel socket of RJ45 is used for Ethernet interface. The pinout of the socket is shown in Figure 7 and described in Table 5.

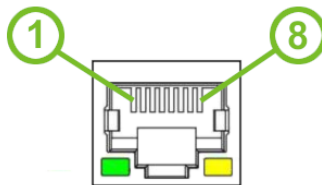

Figure 7: Ethernet Connector Pinout

Pin	Signal mark	Description
1	Tx+	Transmit Data+ (positive pole)
2	Tx-	Transmit Data- (negative pole)
3	Rx+	Receive Data+ (positive pole)
4	—	—
5	—	—
6	Rx-	Receive Data- (negative pole)
7	—	—
8	—	—

Table 5: Ethernet Connector Pinout Description

i The isolation barrier of the Ethernet ports against the ground is 1500 V.

2.3 Power Supply

A two-pin terminal connector (pitch 3.5 mm) is utilized to power the router. The corresponding connector is included as a standard accessory with the router.

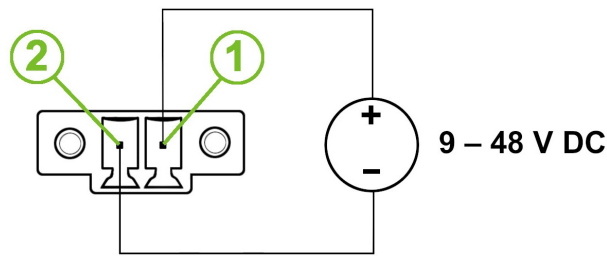

Figure 8: Connection of Power Supply

Pin	Signal mark	Description
1	PWR(+)	Positive pole of DC supply voltage (+9 to +48 V DC)
2	PWR(-)	Negative pole of DC supply voltage

Table 6: Power Supply Pinout

The required power supply voltage for the router ranges between +9 V and +48 V DC. Refer to the connection scheme in Figure 8 for proper setup. The router is equipped with built-in protection against reversed polarity, functioning without signaling. To guarantee correct operation, the power source must be capable of providing a sufficient amount of energy, as detailed in the consumption section of Chapter 3.1.



Unit has to be supplied by a power supply specified as a Limited Power Source (LPS) or CEC/NEC Class 2 source of supply.

All metal parts, including the box, are interconnected with the negative pole of the power supply (common pole). If recommended for the installation environment, protect the router by properly grounding it using the grounding screw, as depicted in Figure 9. The maximum tightening torque for the grounding screw is 1 Nm.

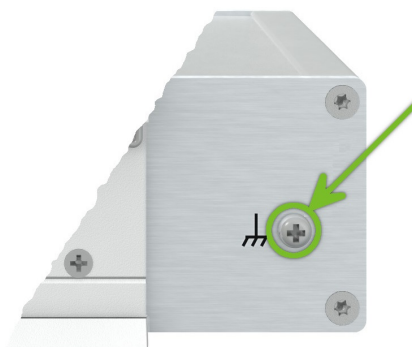

Figure 9: Position of the Grounding Screw

2.4 Low Power Mode



In applications requiring low power consumption (such as solar power - not 7/24 mode) is strictly recommended to use LPM mode prior to powering down the entire router.

LPM (Low Power Mode) is a router mode where the router is in sleep mode with minimal power consumption; see Chapter 3.1 for the LPM consumption. The router can be woken up from this mode after a predetermined period of time. Putting the router into LPM mode can be done using the `lpm` command, see [Command Line Interface](#) application note for more details.

2.5 USB Port

The router is equipped with a single USB 2.0 host port featuring a USB-A type socket. The pinout details of the USB socket are illustrated in Figure 10 and further described in Table 7.

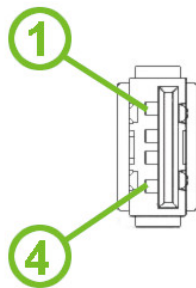

Figure 10: USB Connector Pinout

Pin	Signal Mark	Description	Data Flow Direction
1	+5 V	Positive pole of 5 V DC supply voltage, 0.5 A	
2	USB Data -	USB data signal (negative pole)	Input/Output
3	USB Data +	USB data signal (positive pole)	Input/Output
4	GND	Negative pole of DC supply voltage	

Table 7: USB Connector Pinout

For detailed USB port configuration options, refer to the configuration manual [1], Chapter *Configuration* → *USB Port*.

2.6 LED Status Indication

There are LED indicators on the front panel of the router to provide router status information. Moreover, ETH connector, has two additional LEDs providing information about the port status.

Caption	Color	State	Description
PWR	Green	On	The router is booting up.
	Green	Blinking	The router booted up and is ready.
	Green	Fast blinking	The router firmware is being updated.
ETH0	Green	On	Selected 100 Mbps bit rate
ETH1	Green	Off	Selected 10 Mbps bit rate
ETH0 ETH1	Orange	On	The network cable is connected.
	Orange	Blinking	Data transmission
	Orange	Off	The network cable is not connected.

Table 8: LED Status Indication

2.7 Reset Functions

The *RST* button has multiple functions. For more details, refer to the configuration manual [1], Chapter *Introduction* → *Device* → *Reset*.

-  Use a narrow screwdriver or a small tool to press the *RST* button.



Figure 11: Resetting the Router

3. Technical Specifications

3.1 Basic Parameters

Parameter		Description
Temperature range	Operating	-40 °C to +75 °C
	Storage	-40 °C to +85 °C
Humidity	Operating	5 to 95 % relative humidity non condensing
	Storage	5 to 95 % relative humidity non condensing
Altitude	Operating	2000 m / 70 kPa
Degree of protection		IP30
Supply voltage		9 to 48 V DC
Battery for RTC		CR1225
Consumption for non-WiFi (WiFi) version	Idle	1.4 W (1.8 W)
	Average	1.4 W (1.9 W)
	Maximum	5.3 W (5.8 W)
	LPM mode	3 mW
Dimensions of device w/o clip		113,2 × 80,3 × 42 mm (metal box) 117 × 83,8 × 51,4 mm (plastic box)
DIN rail clip specification		DIN 35 mm, EN 60715
Weight		230 g (metal box) 170 g (plastic box)

Table 9: Basic Parameters

3.2 Standards and Regulations

The router complies with the following standards and regulations:

Parameter	Description
EMC	EN 61000-4-2, EN 61000-4-3, EN 61000-4-4, EN 61000-4-5, EN 61000-4-6, EN 61000-4-11, EN 61000-6-2, EN 61000-6-3, EN 55032
Safety	IEC 62368-1, IEEE 802.3
Transportation	E-Mark (E8), homologation number: 10R-06 13493
National	CE, UKCA compliant
Environmental	REACH, RoHS3 and WEEE compliant

Table 10: Standards and Regulations

3.3 Type Tests and Environmental Conditions

Phenomena	Test	Description	Test levels
ESD	EN 61000-4-2	Enclosure	CD ± 6 kV, L3 AD ± 8 kV, L3
RF field AM modulated	EN 61000-4-3	Enclosure	20 V/m, 80 MHz – 1 GHz, LX 10 V/m, 1 GHz – 6 GHz, L3
Fast transient	EN 61000-4-4	DC ETH - FTP AC/DC	± 1 kV, 5/50Tr/Th ns, 100 kHz, L2 ± 1 kV, 5/50Tr/Th ns, 100 kHz, L3 ± 2 kV, 5/50Tr/Th ns, 100 kHz, L3
Surge	EN 61000-4-5	DC ETH AC/DC	± 1 kV, 1,2/50(8/20) Tr/Th us L2 ± 1 kV, 1,2/50(8/20) Tr/Th us L2 ± 2 kV, 1,2/50(8/20) Tr/Th us L3
RF conducted	EN 61000-4-6	DC ETH AC/DC	10V,0.15-80MHz,80% AM(1kHz),L3 10V,0.15-80MHz,80% AM(1kHz),L3 10V,0.15-80MHz,80% AM(1kHz),L3
Dips & interruptions	EN 61000-4-11	AC/DC	dip 0% 0,5cycle, 0% 1 cycle, 70% 25 cycles, interruption 0% 250 cycles
Radiated emission	EN 55032	Enclosure DC ETH AC/DC	Cl. B,30MHz-1GHz,1GHz-6GHz Class B, 150 kHz – 30 MHz Class B, 150 kHz – 30 MHz Class B, 150 kHz – 30 MHz

Table 11: Type Tests and Environmental Conditions

3.4 Parameters of WiFi

Parameter	Description
Supported Standards	IEEE802.11 ac/a/b/g/n 2.4 GHz / 5 GHz
Antenna Connector	1x RP-SMA Input impedance: 50 Ω
Data Rate	802.11b: 1, 2, 5.5, 11Mbps 802.11a/g: 6, 9, 12, 18, 24, 36, 48, 54 Mbps 802.11n: Max. 72 Mbps @ 20 MHz channel 802.11n: Max. 150 Mbps @ 40 MHz channel
Frequency Ranges	2.4 GHz ISM Bands 2.412-2.472 GHz 5.15-5.25 GHz (FCC UNII-low band) for US/Canada and EU 5.25-5.35 GHz (FCC UNII-middle band) for US/Canada and EU 5.47-5.725 GHz for EU 5.725-5.825 GHz (FCC UNII-high band) for US/Canada
Modulation	DSSS, OFDM, DBPSK, DQPSK, CCK, 16-QAM, 64-QAM
2.4 GHz Channels	1, 2, 3, 4, 5, 6, 7, 8, 9, 10, 11, 12, 13
5 GHz Channels	36, 38, 40, 42, 44, 46, 48, 52, 56, 60, 64, 100, 104, 108, 112, 116, 120, 124, 128, 132, 136, 140, 149, 153, 157, 161, 165
Type of Device	Access point (AP) (up to 8 clients) Station (STA) Multirole (STA&AP)
Security – Standards	WPA, WPA2, WPA3, 802.1X
Security – Encryption	WEP, TKIP, AES
TX Power	Max. 18 dBm @ 2.4 GHz Max. 15 dBm @ 5 GHz

Table 12: Technical Parameters of WiFi

3.5 System Configuration

The main parameters of the system are listed in Table 13.

Parameter	Description
CPU architecture	ARM926EJ-S
CPU frequency	600 MHz
CPU power	4,72 DMIPS/MHz
Flash memory	4 MB of NOR 4 096 MB of eMMC <ul style="list-style-type: none">• 838 MB for Router Apps• 512 MB for customer data• The remaining space is reserved for the system.
RAM size	128 MB
Watchdog	HW Watchdog
RTC	Battery Backup RTC
TPM ¹	Trusted Platform Module (TPM) 2.0

Table 13: System Configuration

¹Not assembled by default, for a dedicated customer order only.

Appendix A: Troubleshooting

If you cannot connect to the router from your PC, your network card may be configured in such a way that it is not possible to connect to the router. Take one or more of the following steps in order to solve the problem:

- Make sure your PC's network card is configured to obtain the IP address from the DHCP server (by default the DHCP server is running in the router).
- Connect the router to the PC via Switch.
- Connect the router to the PC, start the router first and then start the PC after the router's initialization.

Ethernet connection fails or is not establishing.

- It is possible to turn auto negotiation off and set a rate and duplex manually on the Ethernet interface of the router. Available on "LAN Configuration" page in the router.

I cannot connect from the Internet to the device behind the router. I have NAT enabled.

- The device's gateway has to be configured so it points to the router.

I can't access my Web server placed behind the router over NAT.

- The remote HTTP access to the router has to be disabled on "NAT Configuration" page in the router. Also enable "Send all remaining incoming packets to default server" feature and fill in the IP address of your Web server. On the Web server, the default gateway has to be the IP address of the router.

DynDNS doesn't work.

- If the same IP address is recorded in your canonic name as a dynamically assigned address, it means that the provider is using NAT or a firewall.
- You can verify NAT using ping to your server with static address and then compare with router's IP address.
- You can verify a Firewall by accessing remotely to the router's Web interface.
- The operator may not provide the address of DNS server and without DNS server's address it is impossible to connect to the dyndns.org server. The following messages will be shown in the System Log:
 - DynDNS daemon started
 - Error resolving hostname: no such file or directory
 - Connect to DynDNS server failed

L2TP or IPSec isn't establishing.

- Check the "System Log" page for error messages.

IPSec tunnel establishes but the communication does not run.

- Probably there are bad routing rules defined in the connected devices, or the default gateway.

Is the router Cisco compatible? Can I use the Cisco configuration?

- No, the Firmware in the router (ICR-OS) is based on Linux with BusyBox. Thus the Cisco configuration cannot be used. But network connections are defined by standards so connecting the router to the Cisco or other networking devices is possible and will be compatible.

FTP or SFTP does not work

- FTP will work on v2 routers only. You can use SFTP on all routers to transfer files to/from the router. If having troubles with FTP on v2 routers, make sure you have FTP enabled: "Configuration" section, "Services", "FTP". Then you can connect with any client on port 21 with name and password same as for the Web interface. If having troubles with SFTP, make sure you have SSH enabled: "Configuration" section, "Services", "SSH". Then you can connect with any client on port 22 with name and password same as for the Web interface.

How can I connect to the router's command line? (SSH, Telnet)

- You can use SSH on all routers or Telnet on v2 routers only. SSH is enabled by default, but you can verify in Web interface in "Configuration" section, "Services", "SSH". Then connect with any SSH client on port 22 of the router. User and password is the same as for the Web interface. Telnet on v2 routers can be enabled here: "Configuration" section, "Services", "Telnet".

Appendix B: Customer Support

Customer Support for Europe

Advantech Czech s.r.o.

Sokolska 71
562 04, Usti nad Orlici
Czech Republic

Phone: +353 91 792444
Fax: +353 91 792445
E-mail: iiotcustomerservice@advantech.eu
Web: www.advantech.com

Customer Support for NAM

Advantech B+B SmartWorx

707 Dayton Road
Ottawa, IL 61350 USA

Phone: +1-800-346-3119 (Monday – Friday, 7 a.m. to 5:30 p.m. CST)
Fax: +1-815-433-5109
E-mail: support.iiot.ana@advantech.com
Web: www.advantech.com

Customer Support for Asia

Phone: +886-2-2792-7818 #1299 (Monday – Friday, 9 a.m. to 5:30 p.m. UTC+8)
Fax: +886-2-2794-7327
E-mail: icg.support@advantech.com.tw
Web: www.advantech.com

Appendix C: Regulatory & Safety Information

Safety Notices



Please, observe the following instructions:

- The router must adhere to all relevant international and national laws, including any specific restrictions governing its use in designated applications and environments.
- To prevent potential injury and appliance damage, ensure compliance with regulations by using only authorized accessories. Unauthorized modifications or use of unapproved accessories could damage the router, violate regulations, and void the warranty.
- Do not attempt to open the router.
- **Caution!** This equipment is not suitable for use in areas with children.
- Ensure the power supply does not exceed 48 V DC maximum.
- Avoid exposing the router to extreme ambient conditions. Safeguard it against dust, moisture, and high temperatures.
- Only deploy routers with appropriate certification and labeling in environments containing flammable or explosive materials, such as gas stations, chemical plants, or areas involving explosives. Users must observe restrictions pertaining to radio device usage in such settings.
- When traveling by plane, switch off the router. Using it onboard could jeopardize flight operations, disrupt mobile networks, and potentially violate regulations. Non-compliance may result in telephone service suspension, cancellation, or legal repercussions.
- Exercise heightened caution when operating the router near personal medical devices like cardiac pacemakers or hearing aids.
- The router may cause interference when operated in close proximity to TV sets, radio receivers, or personal computers.
- It's advisable to create a suitable backup of all critical settings stored in the device's memory.

Product Disposal Instructions

The WEEE (Waste Electrical and Electronic Equipment: 2012/19/EU) directive was introduced to ensure that electrical/electronic products are recycled using the best available recovery techniques to minimize the environmental impact. This product contains high quality materials and components which can be recycled. At the end of its life this product **MUST NOT** be mixed with other commercial waste for disposal. The device contains a battery. Remove the battery from the device before disposal. The battery in the device needs to be disposed of apart accordingly. Check the terms and conditions of your supplier for disposal information.

Appendix D: Related Documents

[1] *ICR-2[78]00 Configuration Manual* (see *Documents to download* → *Manuals* section)



[EP] Product-related documents and applications can be obtained on **Engineering Portal** at <https://icr.advantech.com/download> address.



We, Advantech Czech s.r.o., declare that the radio equipment narrated in this user's manual complies with Directive **2014/53/EU** (WiFi version) and with the essential requirements and other relevant provisions of Directives **2014/30/EU** and **2014/35/EU** (non-WiFi version).



We, Advantech Czech s.r.o., declare that the radio equipment narrated in this user's manual complies with Radio Equipment Regulations 2017 (**S.I. 2017 No. 1206**) and with the Electromagnetic Compatibility Regulations 2016 (**S.I. 2016 No. 1091** and **S.I. 2016 No. 1101**).

The full text of the EU Declaration of Conformity is available at the following internet address:
icr.advantech.com/doc