

## Hardware Manual

### LAN Cellular Router

## SmartFlex SR300

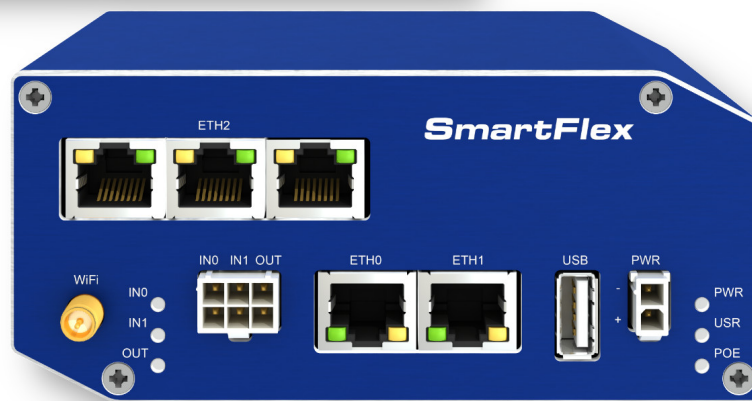
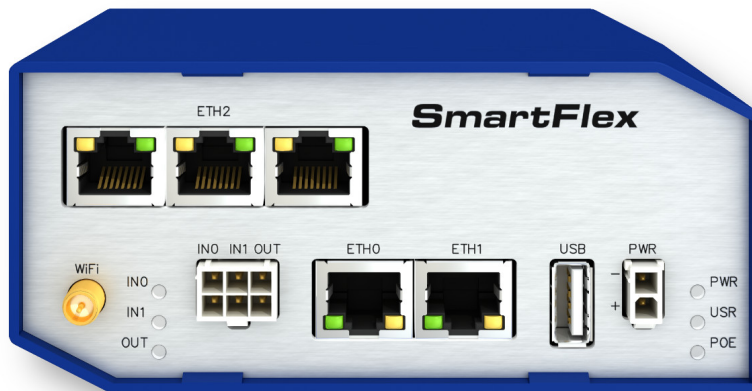

© 2025 Advantech Czech s.r.o. No part of this publication may be reproduced or transmitted in any form or by any means, electronic or mechanical, including photography, recording, or any information storage and retrieval system without written consent. Information in this manual is subject to change without notice, and it does not represent a commitment on the part of Advantech.

Advantech Czech s.r.o. shall not be liable for incidental or consequential damages resulting from the furnishing, performance, or use of this manual.

All brand names used in this manual are the registered trademarks of their respective owners. The use of trademarks or other designations in this publication is for reference purposes only and does not constitute an endorsement by the trademark holder.

# Used symbols



Danger – Information regarding user safety or potential damage to the router.



Attention – Problems that can arise in specific situations.



Information – Useful tips or information of special interest.



# Contents

<b>1. Contents of Package</b>	<b>1</b>
<b>2. Router Design</b>	<b>2</b>
2.1 Router versions . . . . .	2
2.2 Delivery identification . . . . .	3
2.3 Order codes . . . . .	4
2.4 Basic dimensions of the router box . . . . .	6
2.5 Mounting recommendations . . . . .	6
2.6 Removal from the DIN rail . . . . .	6
2.7 Description of the rear panel . . . . .	8
2.8 Description of the front panel . . . . .	8
2.8.1 Status indication . . . . .	9
2.8.2 Power connector PWR . . . . .	10
2.8.3 Antenna connector WiFi . . . . .	11
2.8.4 MicroSD card reader . . . . .	12
2.8.5 Ethernet Ports (ETH0 and ETH1) . . . . .	13
2.8.6 Power over Ethernet (PoE) . . . . .	14
2.8.7 USB Port . . . . .	16
2.8.8 I/O Port . . . . .	17
2.8.9 Reset . . . . .	19
2.9 Interfaces Description . . . . .	20
2.9.1 SWITCH Interface . . . . .	20
<b>3. First Use</b>	<b>21</b>
3.1 Connecting the router before first use . . . . .	21
3.2 Start . . . . .	22
3.3 Configuration . . . . .	22
3.3.1 Configuration over web browser . . . . .	22
<b>4. Technical Parameters</b>	<b>24</b>
4.1 Basic parameters . . . . .	24
4.2 Standards and regulations . . . . .	25
4.3 Type tests and environmental conditions . . . . .	26
4.4 Technical parameters of WiFi . . . . .	27
4.5 Technical parameters of I/O port . . . . .	27
4.6 Technical Parameters of Power over Ethernet (PoE) . . . . .	28
4.7 Other Technical Parameters . . . . .	28
<b>Appendix A: Troubleshooting</b>	<b>29</b>
<b>Appendix B: Customer Support</b>	<b>32</b>
<b>Appendix C: Regulatory &amp; Safety Information</b>	<b>33</b>
<b>Appendix D: Related Documents</b>	<b>34</b>

# List of Figures

1	Contents of package . . . . .	1
2	Version SWITCH (plastic) . . . . .	2
3	Version SWITCH and WiFi (plastic) . . . . .	2
4	Version SWITCH (metal) . . . . .	2
5	Version SWITCH and WiFi (metal) . . . . .	2
6	Label example . . . . .	3
7	Basic dimensions of the router box . . . . .	6
8	Default position of plastic and metal DIN rail clip . . . . .	7
9	Removal from the DIN rail . . . . .	7
10	SPECTRE v3 ERT front panel . . . . .	8
11	Power connector . . . . .	10
12	Connection of power supply . . . . .	10
13	Antenna connector . . . . .	11
14	MicroSD card . . . . .	12
15	Ethernet connector . . . . .	13
16	Connection of Ethernet cable . . . . .	13
17	PoE PD usage . . . . .	14
18	PoE PSE usage . . . . .	15
19	USB connector . . . . .	16
20	I/O connector . . . . .	17
21	Binary connection . . . . .	18
22	Router reset . . . . .	19
23	Version with SWITCH board . . . . .	20
24	Router connection . . . . .	21
25	Entering the IP address of the router . . . . .	22
26	Entering login information . . . . .	22
27	Router web interface . . . . .	23

# List of Tables

1	Router versions . . . . .	2
2	Delivery identification . . . . .	3
3	Order codes overview . . . . .	4
4	Power over Ethernet . . . . .	4
5	Type of router box . . . . .	5
6	Type of power supply . . . . .	5
7	Examples of order code . . . . .	5
8	Front panel description . . . . .	8
9	LED status indication . . . . .	9
10	Connection of power connector . . . . .	10
11	Technical specifications of microSD card . . . . .	12
12	Ethernet connector pinout . . . . .	13
13	Insulation strength of Ethernet ports . . . . .	13
14	Connection of USB connector . . . . .	16
15	Connection of I/O port . . . . .	17
16	Characteristics of inputs . . . . .	17
17	Description of reset and restart router . . . . .	19
18	State indication of the SWITCH interface . . . . .	20
19	SWITCH interface parameters . . . . .	20
20	Basic parameters . . . . .	24
21	Standards and Regulations . . . . .	25
22	Type tests and environmental conditions . . . . .	26
23	Technical parameters of WiFi . . . . .	27
24	Characteristics of inputs . . . . .	27
25	PoE PD: parameters for opposite PSE . . . . .	28
26	PoE PSE parameters . . . . .	28
27	Other technical parameters . . . . .	28

# 1. Contents of Package



Basic delivered set of router includes:

- router,
- power supply,
- crossover UTP cable,
- 2.4 GHz WiFi antenna (**only for version with WiFi**),
- loose power and I/O connector (+8 pins<sup>1</sup>),
- clip for the DIN rail,
- printed *Quick Start Guide Leaflet*.



Figure 1: Contents of package



Temperature range for power supply is reduced to 0 °C to +40 °C!

<sup>1</sup>These pins are designed for cables with a diameter from 0.2 to 0.8 mm<sup>2</sup>

# 2. Router Design

## 2.1 Router versions



Check with your local Advantech sales representative for available options and HW configurations.

SmartFlex SR300 router is supplied in the following versions (see table below). All versions are available in plastic or metal box according to customer requirements. All versions are available with PoE PD (Power over Ethernet – powered device) so you can power the router from both ETH0 and ETH1 interfaces, or with PoE PSE (power source equipment) so you can power other devices by the router.

Router versions	BIN	BOUT	USB	SD	ETH	WiFi
Version with SWITCH board	2 x	1 x	1 x	1 x	5 x	
Version with SWITCH board & WiFi	2 x	1 x	1 x	1 x	5 x	1 x

Table 1: Router versions

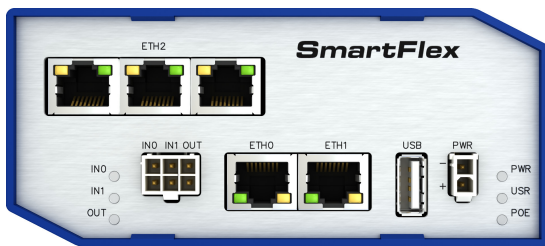

Figure 2: Version SWITCH (plastic)

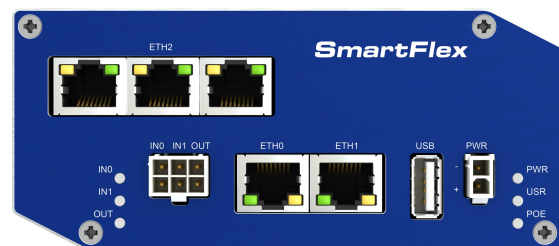

Figure 4: Version SWITCH (metal)

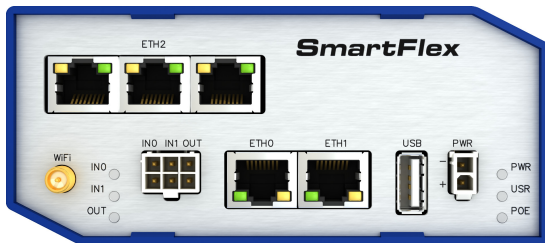

Figure 3: Version SWITCH and WiFi (plastic)

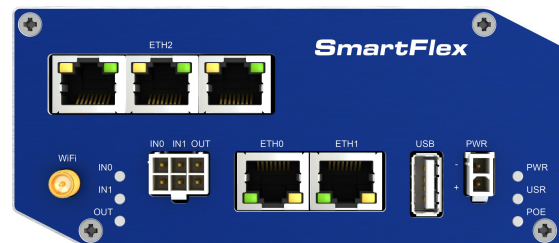

Figure 5: Version SWITCH and WiFi (metal)



## 2.2 Delivery identification

Trade name	Product name	Description
SmartFlex SR300	SmartFlex	Router in a plastic or metal box

Table 2: Delivery identification

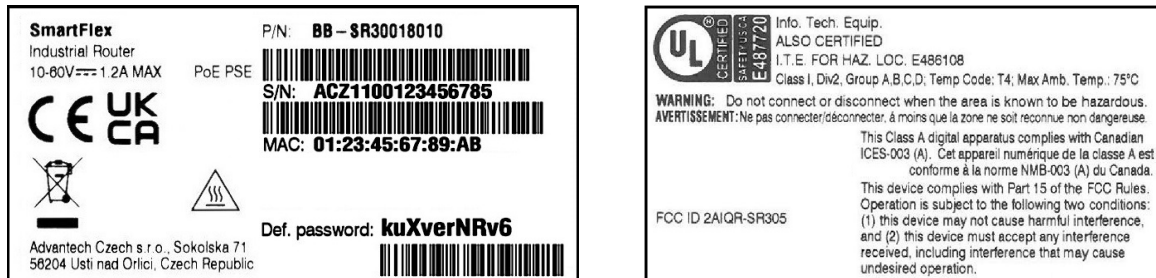

Figure 6: Label example

## 2.3 Order codes

Order codes overview is shown in the table below.

Product Name	Order code	Features – interfaces
SR300	BB-SR3000xyz*	5x ETH, 1x USB, 2x BI, 1x BO, 1x microSD reader,
SR300	BB-SR3001xyz*	5x ETH, 1x USB, 2x BI, 1x BO, 1x microSD reader, WiFi

Table 3: Order codes overview



\* Replace the letters "x", "y" and "z" with the values from the following tables:

### Letter "x" – Power over Ethernet (PoE)

Power over Ethernet (PoE)	Number "x" in code
Version without PoE	0
PoE PSE – Power Source Equipment – powers other devices	8
PoE PD – Powered Device – can be powered via Ethernet	9

Table 4: Power over Ethernet

**Letter "y" – type of the router box**

Type of box	Number "y" in code
Plastic	1
Metal	2

Table 5: Type of router box

**Letter "z" – type of the power supply connector**

Type of power supply	Number "z" in code
Without accessories	0
European	1
Interchangeable plug adapters (EU, US, UK, AUS)	5

Table 6: Type of power supply

Examples of complete order code:

Order code	Features – interfaces	Box	Power supply
BB-SR30008111	5x ETH, 1x USB, 2x BI, 1x BO, 1x microSD reader, PoE PSE	plastic	Europe
BB-SR30019121	5x ETH, 1x USB, 2x BI, 1x BO, 1x microSD reader, WiFi, PoE PD	metal	Europe
BB-SR30000113	5x ETH, 1x USB, 2x BI, 1x BO, 1x microSD reader	plastic	Australia
BB-SR30010120	5x ETH, 1x USB, 2x BI, 1x BO, 1x microSD reader, WiFi	metal	None

Table 7: Examples of order code

## 2.4 Basic dimensions of the router box

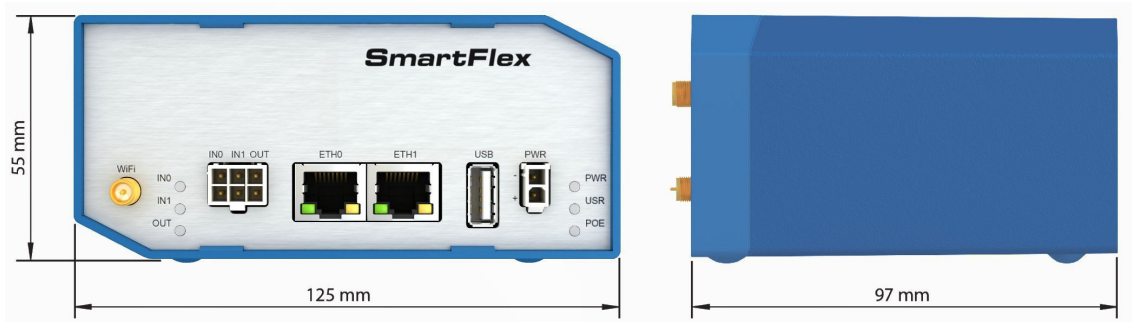

Figure 7: Basic dimensions of the router box

## 2.5 Mounting recommendations

- Possibility to be put on a work surface,
- DIN rail EN 60715 with included plastic or metal clip.

For the most of applications with a built-in router in a switch board it is possible to recognize two kinds of environments:

- no public and industry environment of low voltage with high interference,
- public environment of low voltage without high interference.

For both of these environments, it is possible to mount router to a switch board, the following there is no need to have examination immunity or issues in connection with EMC according to EN 60439-1 ed.2:00 + A1:04.



Compliance of EN 60439-1 ed.2:00 + A1:04 specification it is necessary to observe next assembly of the router to the switch – board:

- For every cables we recommend to bind the bunch, we recommend for this use:
  - Length of the bunch (the combination of power supply and data cables) can be maximum 1.5 m. If the length of data cables exceeds 1.5 m or in the event of, the cable leads towards the switch – board. We recommend installing over – voltage protectors (surge suppressors).
  - With data cables they mustn't carry cables with reticular tension  $\sim 230$  V/50 Hz.
- Sufficient space must be left before individual connectors for handling of cables,
- For correct function of the router we recommend to use in the switch-board earth-bonding distribution frame for grounding of power supply of router, data cables and antenna.

## 2.6 Removal from the DIN rail

The DIN rail clip is suitable for a DIN rail according to EN 60715 standard only. The default position of plastic or metal rail clip, which is used for mounting the router on a DIN rail, is shown in the following figure. Its position can be changed on some models (back or bottom). When changing the position of the DIN rail clip, tighten the screws with max. 0.4 Nm torque.

To remove the router from the DIN rail, push the router down lightly, so the bottom part of the DIN rail clip (hitched to the DIN rail) gets out of the rail and then pull out the bottom part of the router away from the DIN rail.

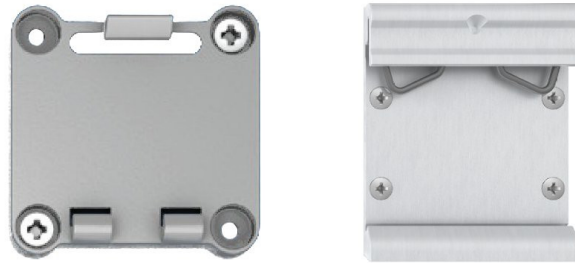

Figure 8: Default position of plastic and metal DIN rail clip

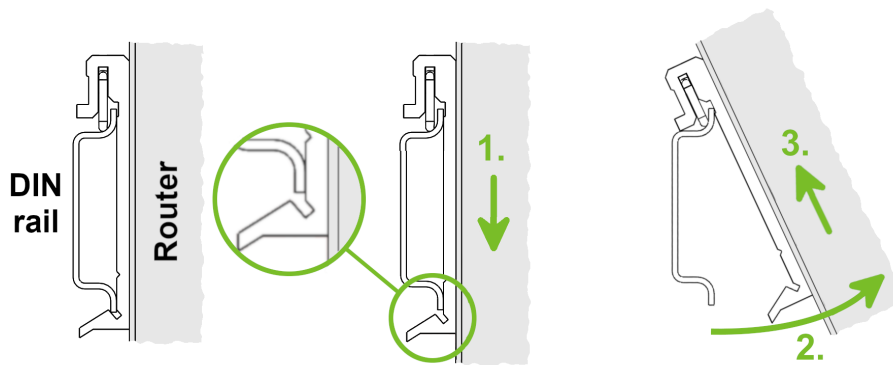

Figure 9: Removal from the DIN rail

## 2.7 Description of the rear panel

The rear panel contains only one holder for SD card (*SD*) and *RST* button used to restore default configuration and reboot the router.

## 2.8 Description of the front panel

On the front panel is the following:

Caption	Connector	Description
PWR	2-pin	Connector for the power supply
ETH0	RJ45	Connector for connection into the computer network, PoE (only for PoE PSE or PoE PD versions)
ETH1	RJ45	Connector for connection into the computer network, PoE (only for PoE PSE or PoE PD versions)
WiFi	R-SMA	Connector for WiFi antenna ( <b>only for versions with WiFi module!</b> )
USB	USB-A 2.0 Host	Connector for connection of USB devices to the router. Supports devices with PL-2303 and FTDI USB/RS232 converters.
I/O	6-pin	Connector for connection of the binary inputs and output

Table 8: Front panel description

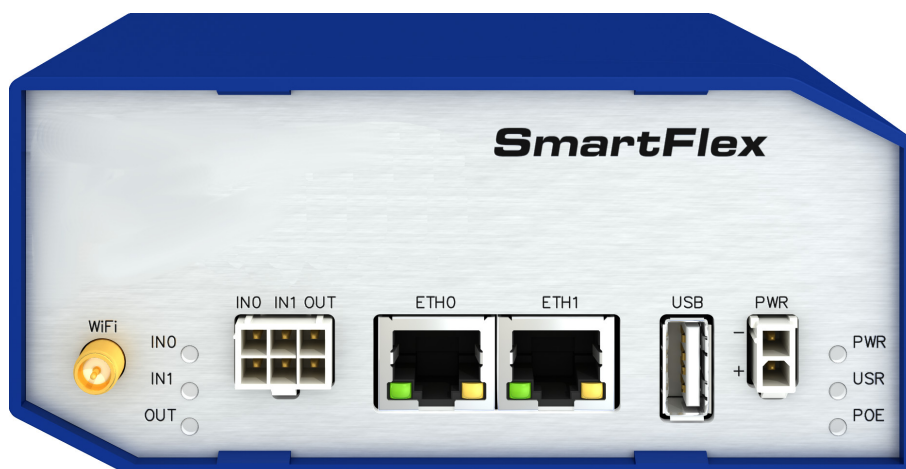

Figure 10: SPECTRE v3 ERT front panel

### 2.8.1 Status indication

There are status LEDs on the front panel to provide router status information. Each ETH port has two additional LEDs that provide information about the port status.

Caption	Color	State	Description
PWR	Green	Blinking On Fast blinking	The router is booting up. The router booted up and is ready. The router firmware is being updated.
USR	Yellow	—	The function of this LED is user-defined.
POE	Yellow Green	On Blinking On  Blinking Off	PSE: The insufficient voltage on the PWR connector. PSE: The powered device takes too much power. <sup>1</sup> PD: The power supply is present on an ETH port. PSE: A correct power supply on the PWR connector. PSE: A device is powered via one of the ETH ports. PD: The power supply is not present on an ETH port. PSE: The PoE disabled in the Ethernet configuration.
IN0	Green	On	The first binary input is active.
IN1	Green	On	The second binary input is active.
OUT	Yellow	On	The binary output is active.
ETH0 ETH1	Green	On Off	Selected 100 Mbit/s Selected 10 Mbit/s
ETH0 ETH1	Yellow	On Blinking Off	The network cable is connected Data transmission The network cable is not connected

Table 9: LED status indication

<sup>1</sup>Additionally it can indicate a device without PoE support connected on the other side of the cable. In this case the indication is caused by low impedance (lower than 500  $\Omega$ ) of the device without PoE support. This can be solved by disabling the PoE PSE feature on the relevant ETH port in the router's Web interface, see *Configuration manual* [1].

## 2.8.2 Power connector PWR

Panel socket 2-pin.

Pin number	Signal mark	Description
1	GND(-)	Negative pole of DC supply voltage
2	VCC(+)	Positive pole of DC supply voltage (+10 to +60 V DC)

Table 10: Connection of power connector

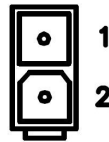

Figure 11: Power connector



Unit has to be supplied by a power supply specified as a Limited Power Source (LPS) according to Annex Q of IEC 62368-1. If the power supply/cable provided with device is not used, always use the cables with minimum wire size (nominal cross section) 0.5 square mm for power supply.

The power supply for the router must be between +10 V to +60 V DC supply. Protection against reversed polarity without signaling is built into the router. **Note:** The protection against reversed polarity is lost if the negative pole is grounded!



Circuit example:

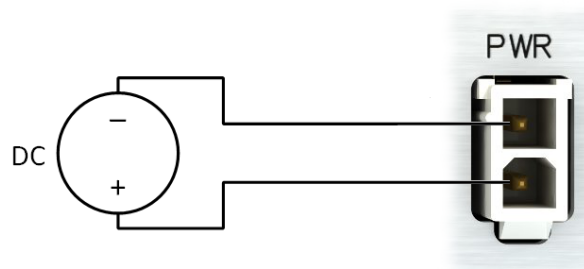

Figure 12: Connection of power supply



**Note for PoE:** See Chapter 2.8.6 for information on how PoE versions of the router impact the power supply usage. The power supply for a PoE router has to meet other specific requirements.



All metal parts are connected together with the negative pole of power supply (common pole).

### Low Power Mode



In applications requiring low power consumption (such as solar power - not 7/24 mode) is strictly recommended to use LPM mode prior to powering down the entire router.

LPM (Low Power Mode) is a router mode where the router is in sleep mode with minimal power consumption. The router can be woken up from this mode by a signal applied to the BIN1 input or after a predetermined period of time. Putting the router into LPM mode can be done using the `lpm` command, see [Command Line Interface](#) application note for more details. Consumption in LPM mode may vary depending on the configuration of the router.



### 2.8.3 Antenna connector WiFi

If the router is equipped with WiFi module on the customer's request, appropriate antenna is connected to the reverse SMA connector (*WiFi*).



The external antenna is connected by screwing this antenna to the reverse SMA connector on the router's front panel (see the figure below).

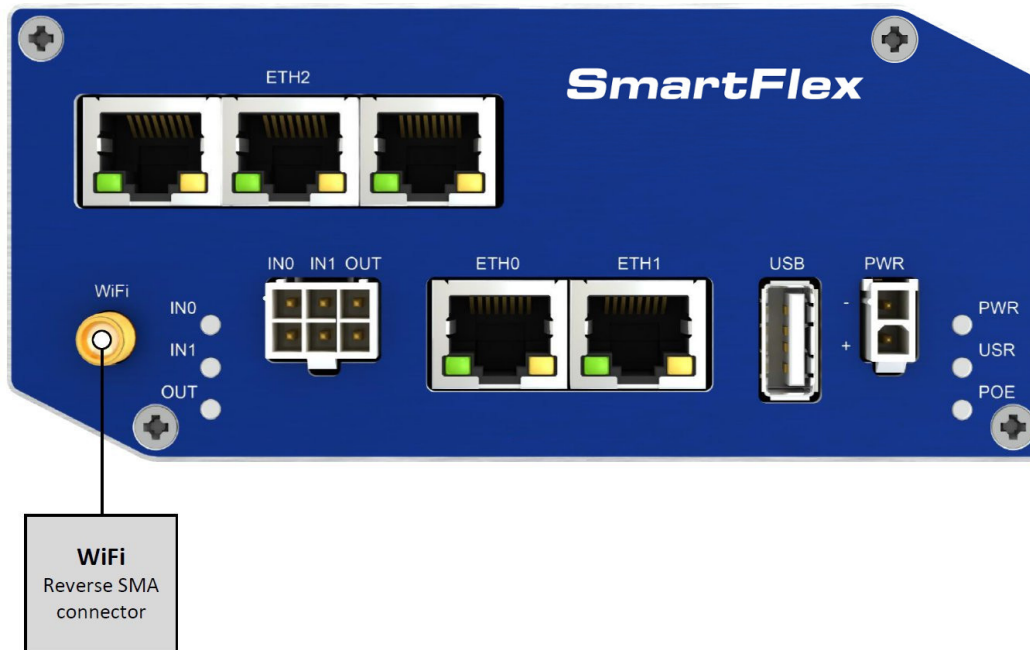

Figure 13: Antenna connector

### 2.8.4 microSD card reader

The microSD card reader is placed on the rear panel of the router (there is only a single slot). This card reader allows the router to operate with memory cards microSD. Technical specifications are stated in the table below.

Technical specifications of microSD card		
Supported technologies	SDHC, SDXC	
Supported capacity	SDHC SDXC	up to 32 GB from 32 GB to 64 GB
Supported microSD card filesystems	vfat, ext2, ext3, ext4	

Table 11: Technical specifications of microSD card

#### Changing the microSD card:

- Use the flat end of a spudger, or your fingernail, to press the microSD card slightly deeper into its slot until you hear a click.
- After the click, release the card and it will pop out of its slot.
- Remove the microSD card and push any other microSD card into the slot until it clicks in place.

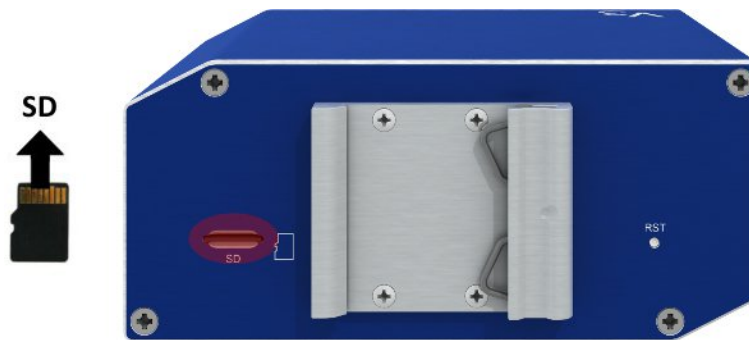

Figure 14: MicroSD card

#### Mounting microSD Card to the System

It is necessary to mount the microSD card to be able to access it in the system of the router. Follow these steps to mount the card:

- Use the `dmesg` command to see the list of recently connected devices.
- In the output of the command find out the entry for the microSD card, for example:  
`mmcblk0: p1`
- To mount the card to `mnt` directory, use the `mount` command:  
`mount /dev/mmcblk0p1 /mnt`



For more information about the commands for creating, mounting, checking and unmounting a file system on a microSD card, see the application note for [Ext4 Filesystem Utilities](#) router app.

### 2.8.5 Ethernet Ports (ETH0 and ETH1)

The panel socket RJ45 is used for this interface. The isolation barrier of the Ethernet signal ports against the ground is 1500 V.

Pin	10base-T & 100base-T	PoE (Mode B)
1	Tx+ (Transmit Data+)	—
2	Tx- (Transmit Data-)	—
3	Rx+ (Receive Data+)	—
4	—	PoE + (positive pole)
5	—	PoE + (positive pole)
6	Rx- (Receive Data-)	—
7	—	PoE - (negative pole)
8	—	PoE - (negative pole)

Table 12: Ethernet connector pinout

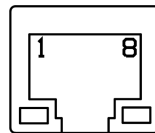

Figure 15: Ethernet connector

The crossover UTP cable (Ethernet cable) plugs into the RJ45 connector labeled as ETH0 or ETH1 (see the figure below).

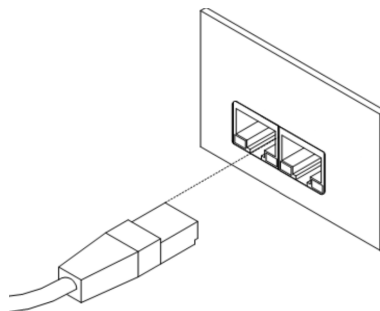

Figure 16: Connection of Ethernet cable







The insulation strength of Ethernet ports from each other and from the rest of the router (grounding) is dependent on the router version:

Router Version	Insul. Strength from Router	Insul. Strength between Ports
Without PoE	1.5 kV	1.5 kV
PoE PD	1.5 kV	none
PoE PSE	none	none

Table 13: Insulation strength of Ethernet ports

## 2.8.6 Power over Ethernet (PoE)

-  Available only for models with PoE feature; see Chapter 2.3 for the order codes.
-  You can not power the router via the ETH2 ports on the SWITCH router version. The PoE PD is available on the ETH0 and ETH1 ports only.
-  The *IEEE 802.3af/PoE* (Type 1) and *IEEE 802.3at/PoE+* (Type 2) standards are supported. The device is Mode B compliant.
-  You can use the `pse` command to control the PoE functionality; see the [Commands and Scripts](#) application note.

Based on the model configuration, the PoE PSE or PoE PD feature can be supported for both Ethernet ports (ETH0 and ETH1).

The PoE PSE version allows the router to power other devices over the Ethernet. The PoE PD version enables the router to be powered by another PoE PSE device over the Ethernet.

### PoE PD

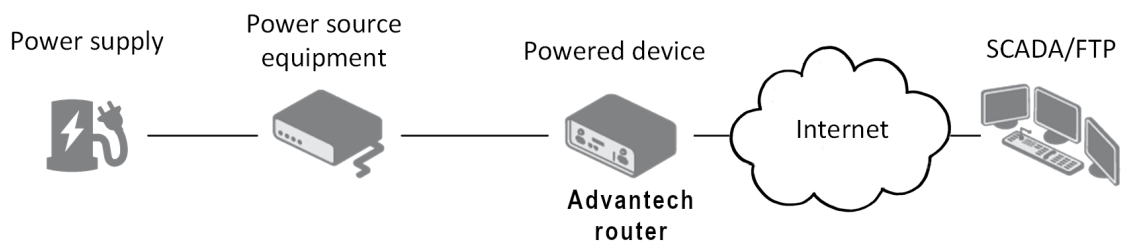

Figure 17: PoE PD usage

The PoE PD parameters can be found in Chapter 4.6. The POE LED on the front panel of the router lights up green when voltage is present on an Ethernet port, so the user knows the router can be PoE powered. You can still power the router with this connector even if the router is powered with PoE (in PoE PD version), but the input voltage must be higher than 15 V DC. If the input voltage is lower than 15 V DC and the PoE voltage is present (POE LED green on), the router will still be powered from the Ethernet connector via PoE.

## PoE PSE

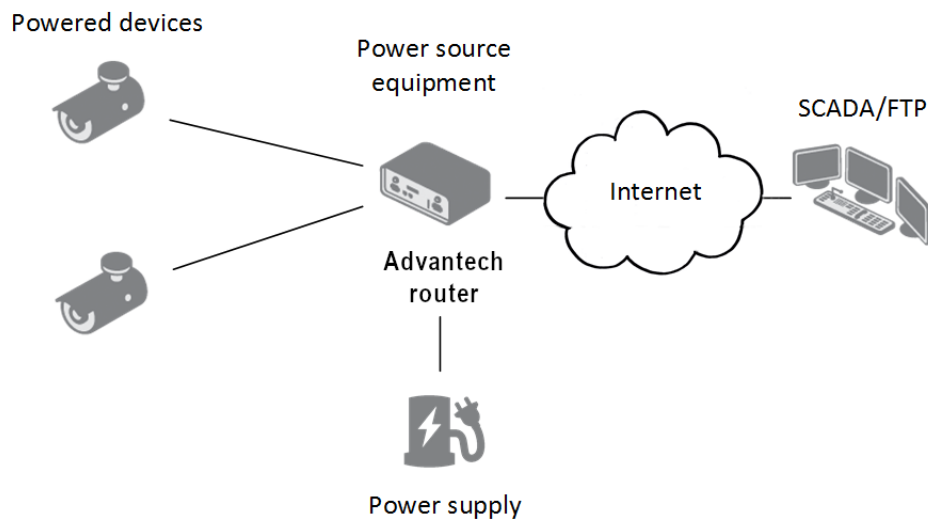

Figure 18: PoE PSE usage

**!** The power supply used with the PoE PSE router has to provide voltage from 44 to 57 V DC and the output power has to be at least 65 W for full PoE+ use (Class 4) in both Ethernet ports (ETH0 and ETH1).

The PoE PSE parameters can be found in Chapter 4.6. The PoE state is indicated by the POE LED on the front panel of the router, see Chap. 2.8.1. When sufficient voltage (44 to 57 V) and power is available is indicated by the green light. A yellow POE LED indicates insufficient power or voltage through the PWR connector. When a device is being powered from the router, the POE LED will be blinking green. Yellow blinking is shown for an overload (the powered device is using too much power) or a short circuit (incorrect wiring of the cable or of the device without PoE support).

You can enable or disable the PoE PSE feature separately on the ETH0 and ETH1 ports via the Web interface of the router. This can be found in the LAN configuration pages (*Primary* for ETH0, *Secondary* for ETH1). When PoE PSE is enabled, you can find the current, voltage, power and power class information on the *General* page of the router's Web interface; see the *Configuration manual* [1].

### 2.8.7 USB Port

Panel socket USB-A.

Pin	Signal mark	Description	Data flow direction
1	+5 V	Positive pole of 5 V DC supply voltage, 0.5 A	
2	USB data -	USB data signal – negative pole	Input/Output
3	USB data +	USB data signal – positive pole	Input/Output
4	GND	Negative pole of DC supply voltage	

Table 14: Connection of USB connector



Figure 19: USB connector



The USB port is disabled on overload to prevent its damage (connected device is trying to get too high current). The port is enabled again after the reboot of the router.

#### Mounting USB Flash Drive to the System

It is necessary to mount the USB flash drive to be able to access it in the system of the router. Follow these steps to mount the drive:

- Use the `dmesg` command to see the list of recently connected devices.
- In the output of the command find out the entry for the microSD card, for example:  
`sda: sda1`
- To mount the card to `mnt` directory, use the `mount` command:  
`mount /dev/sda1 /mnt`



For more information about the commands for creating, mounting, checking and unmounting a file system on a USB Flash Drive, see the application note for [Ext4 Filesystem Utilities](#) router app.

### 2.8.8 I/O Port

Panel socket 6-pin.

Pin	Signal mark	Description
1	IN0	Binary input 0
2	IN0	Binary input 0
3	IN1	Binary input 1
4	IN1	Binary input 1
5	OUT	Binary output
6	OUT	Binary output

Table 15: Connection of I/O port

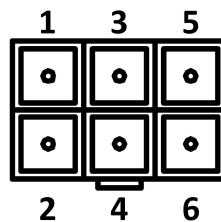

Figure 20: I/O connector

The I/O user Interface is designed for the processing of binary input and control (setting) of binary output. Binary output is open in the default configuration. The isolation strength is 1.5kV. The pins are isolated from each other with the same strength.

The input circuits are bipolar and allow connection as needed with common plus or minus (according to the connection of an external voltage).

#### Binary inputs

- Characteristics of inputs:

Logical 0 / 1*	Voltage	Current	Web interface status
log. 1 max	3 V	0.4 mA	Off
log. 0 min	5 V	0.7 mA	On
log. 0 type	12 V	2 mA	On
log. 0 max	60 V	7 mA	On

Table 16: Characteristics of inputs

\* The binary input status in the Shell is returned via `io get bin0` or `io get bin1`.

### Binary output

- Binary output parameters:
  - 60 V AC / 300 mA
  - 60 V DC / 300 mA
- The current of the binary output is limited by a resettable fuse (300 mA).

### Binary inputs and output connections

Binary inputs and output connections example:

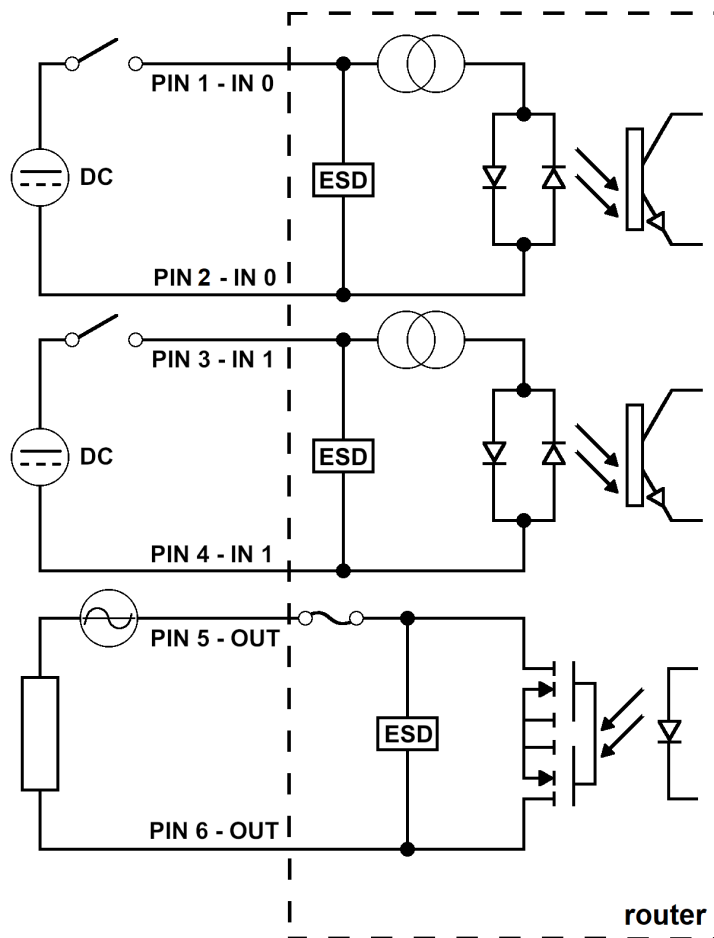



Figure 21: Binary connection



### 2.8.9 Reset

When *PWR* LED starts flashing on the front panel, it is possible to restore the default configuration of the router by pressing the *RST* button on the rear panel. After pressing this button the default configuration is restored and then router reboots (green LED will be on).

 For pressing the *RST* button could be used a narrow screwdriver.

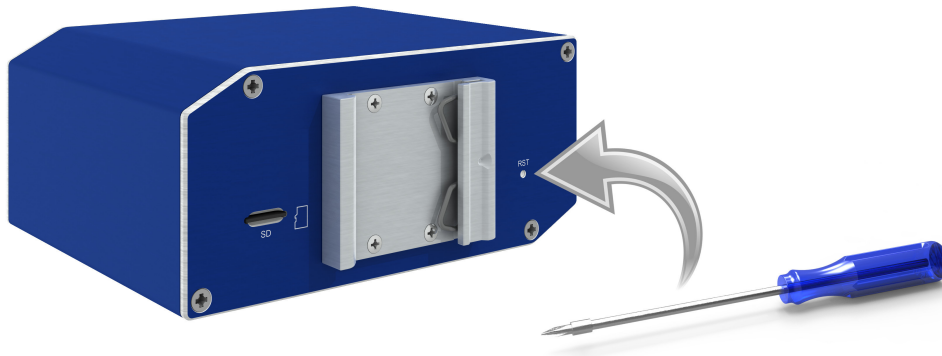

Figure 22: Router reset



We recommend backing up configuration of the router (see *Configuration manual*) because reset of the router sets the configuration to the default state.

It is important to distinguish between reset and reboot the router.

Action	Router behavior	Invoking events
Reboot	Turn off and then turn on router	Disconnect and connect the power, Press the <i>Reboot</i> button in the web configuration
Reset	Restore default configuration and reboot the router	Press <i>RST</i> button

Table 17: Description of reset and restart router

## 2.9 Interfaces Description

There are available versions with one of the following interfaces:

- SWITCH interface

### 2.9.1 SWITCH Interface

Three LAN ports of SWITCH interface for SmartFlex routers (RJ45 connectors for connecting Ethernet devices) act as a typical switch device. This means that the router reads Ethernet frames (data packets on an Ethernet link) from any port on SWITCH interface and transmits them on other ports of the SWITCH interface. Each port can transmit frames independently on the other ports. State indication is provided on every connector. Router in this version complies with the standards and temperature ranges declared in Chap. efchap:BasicParams except for the lower maximum operating temperature which is +70 °C.

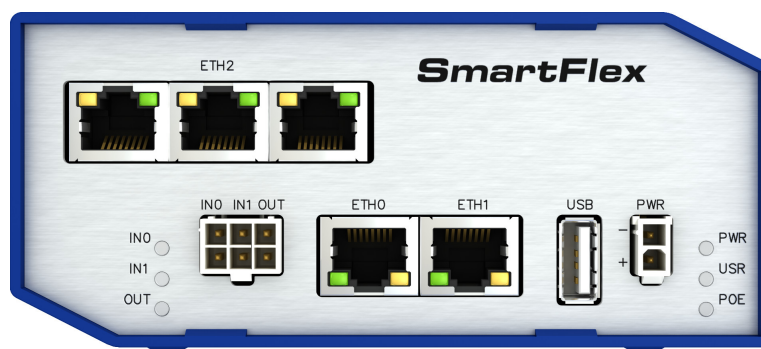

Figure 23: Version with SWITCH board

State indication of the interface:

Description of indication		
Green LED	On	Selected 100 Mbps
	Off	Selected 10 Mbps
Yellow LED	On	The network cable is connected
	Blinking	Data transmission
	Off	The network cable is not connected

Table 18: State indication of the SWITCH interface

Technical specification of Ethernet IEEE 802.3:

Ethernet interface, IEEE 802.3 standard	
Maximum data rate	100 Mbps
Max. total cable length (300 Bd, 200 nF/km)	100 m

Table 19: SWITCH interface parameters

# 3. First Use

## 3.1 Connecting the router before first use

Before putting the router into operation it is necessary to connect all components which are required to run your applications.

**!** The router can not operate without connected power supply.

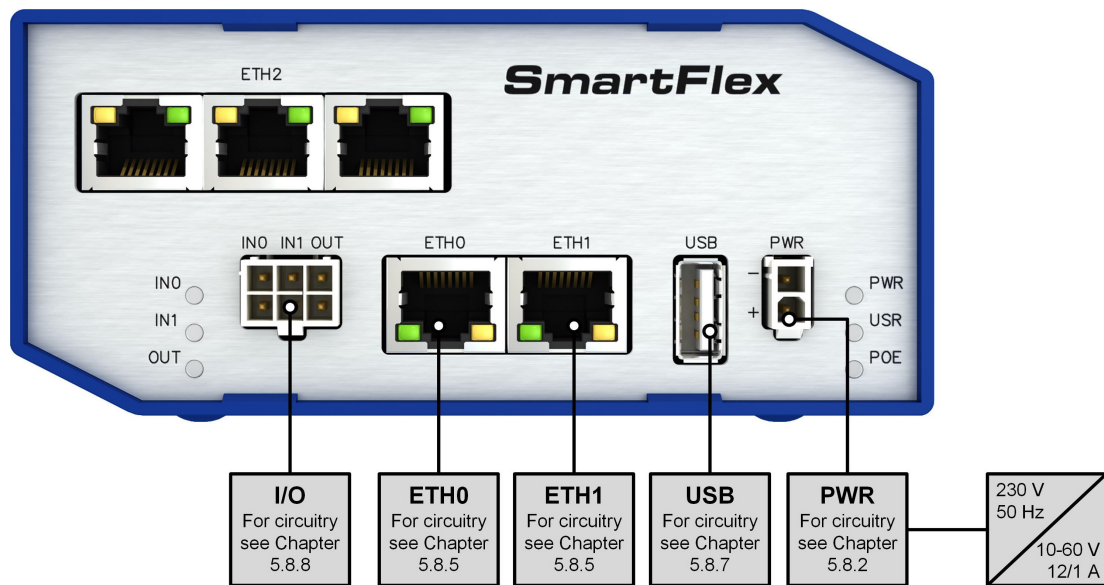

Figure 24: Router connection

### 3.2 Start

The router is put into operation when the power supply is connected to this router. By default, the router will automatically start to log on to the default APN. DHCP server will start to assign addresses for devices on the Ethernet port ETH0. Router’s behavior can be changed via the web interface. This is described in detail in the *Configuration manual for SmartFlex routers*.

### 3.3 Configuration

#### 3.3.1 Configuration over web browser

For status monitoring, configuration and administration of the router is available a web interface which can be accessed by entering the IP address of the router into the web browser. The default IP address of the router is 192.168.1.1. Attention, it is necessary to use HTTPS protocol for secure communication over a network!

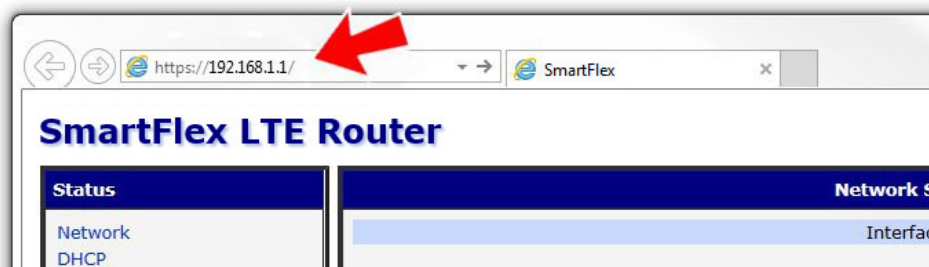

Figure 25: Entering the IP address of the router

Configuration may be performed only by the user "root". The default password is printed on the router’s label.<sup>1</sup> Change the default password as soon as possible!



All routers have the *WebAccess/DMP* client pre-installed by default. The activated client periodically uploads router identifiers and configuration to the *WebAccess/DMP* server. See the configuration manual [1], chapter *Basic Information* → *WebAccess/DMP Configuration*, for more information.

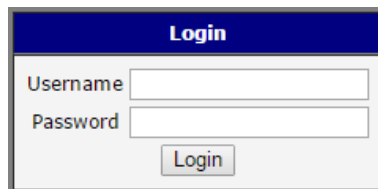

Figure 26: Entering login information

After successfully entering login information user gains access to the router via his internet browser.



A detailed description of the router settings via the Web interface can be found in the document *Configuration manual for SmartFlex routers*.

<sup>1</sup>If the router’s label does not contain a unique password, use the password "root".

Status	General Status
<ul style="list-style-type: none"> <li>General</li> <li>WIFI</li> <li>WIFI Scan</li> <li>Network</li> <li>DHCP</li> <li>IPsec</li> <li>DynDNS</li> <li>System Log</li> </ul>	<div style="background-color: #e0e0e0; padding: 2px; text-align: center;">Primary LAN</div> <p>IP Address : 10.40.28.66 / 255.255.252.0                      MAC Address : 7C:66:9D:38:30:F0                      Rx Data : 10.4 KB                      Tx Data : 21.0 KB</p> <p style="text-align: center;">» More Information «</p>
<b>Configuration</b>	<div style="background-color: #e0e0e0; padding: 2px; text-align: center;">Secondary LAN</div> <p>IP Address : Unassigned                      MAC Address : 7C:66:9D:38:30:F2</p> <p style="text-align: center;">» More Information «</p>
<ul style="list-style-type: none"> <li>LAN</li> <li>VRRP</li> <li>PPPoE</li> <li>WIFI</li> <li>WLAN</li> <li>Backup Routes</li> <li>Firewall</li> <li>NAT</li> <li>OpenVPN</li> <li>IPsec</li> <li>GRE</li> <li>L2TP</li> <li>PPTP</li> <li>DynDNS</li> <li>NTP</li> <li>SNMP</li> <li>SMTP</li> <li>Expansion Port 1</li> <li>Expansion Port 2</li> <li>USB Port</li> <li>Startup Script</li> <li>Up/Down Script</li> <li>Automatic Update</li> </ul>	<div style="background-color: #e0e0e0; padding: 2px; text-align: center;">WIFI</div> <p>IP Address : Unassigned                      MAC Address : 78:A5:04:22:2A:67</p> <p style="text-align: center;">» More Information «</p>
<b>Customization</b>	<div style="background-color: #e0e0e0; padding: 2px; text-align: center;">Peripheral Ports</div> <p>Expansion Port 1 : RS-232                      Expansion Port 2 : RS-485                      Binary Input 0 : Off                      Binary Input 1 : Off                      Binary Output : Off</p>
<b>Administration</b>	<div style="background-color: #e0e0e0; padding: 2px; text-align: center;">System Information</div> <p>Firmware Version : 5.2.1 (2015-07-17)                      Serial Number : N/A                      Profile : Standard                      Supply Voltage : 11.9 V                      Temperature : 39 °C                      Time : 2000-03-27 01:07:57                      Uptime : 0 days, 0 hours, 0 minutes</p>
<ul style="list-style-type: none"> <li>User Modules</li> </ul>	
<b>Administration</b>	
<ul style="list-style-type: none"> <li>Change Profile</li> <li><b>Change Password</b></li> <li>Set Real Time Clock</li> <li>Backup Configuration</li> <li>Restore Configuration</li> <li>Update Firmware</li> <li>Reboot</li> </ul>	

Figure 27: Router web interface

# 4. Technical Parameters

## 4.1 Basic parameters

SmartFlex SR300		
Temperature range	Operating Storage	-40 °C to +80 °C -40 °C to +85 °C
Cold start		-40 °C
Humidity	Operating Storage	0 to 95 % relative humidity non condensing 0 to 95 % relative humidity non condensing
Altitude	Operating	2000 m / 70 kPa
Degree of protection		IP30
Supply voltage		10 to 60 V DC
Battery for RTC		CR1225
Consumption	Idle Average Peak Sleep mode	2 W 3.3 W 4.5 W 10 mW
Dimensions		55 x 97 x 125 mm (DIN 35 mm, EN 60715)
Weight	Plastic box Metal box	approximately 211 g (depends on interface) approximately 327 g (depends on interface)
Antenna connectors		Reverse SMA – 50 Ω (only for versions with WiFi module)
User interface	2x ETH USB I/O Micro SD	Ethernet (10/100 Mbps) USB 2.0 6-pin panel socket SDHC, SDXC

Table 20: Basic parameters

## 4.2 Standards and regulations

The router complies with the following standards and regulations:

Parameter	Description
Radio	ETSI EN 300 328, ETSI EN 301 893
EMC	ETSI EN 301 489-1, ETSI EN 301 489-1, ETSI EN 301 489-17
Safety	IEC 62368-1 (UL E487720), EN 62311 <b>UL C1D2</b> UL E486108 *
National	CE, UKCA compliant

Table 21: Standards and Regulations

\* Excluding versions with PoE PSE.

### 4.3 Type tests and environmental conditions

Phenomena	Test	Description	Test levels
ESD	EN 61000-4-2	Enclosure contact Enclosure air	$\pm 6$ kV (crit. A) $\pm 8$ kV (crit. A)
RF field AM modulated	EN 61000-4-3	Enclosure	20 V/m (crit. A) (80 – 2700 MHz) 3 V/m (crit. A) (2700 – 6000 MHz)
Fast transient	EN 61000-4-4	Signal ports Power ports Ethernet ports	$\pm 2$ kV (crit. A) $\pm 2$ kV (crit. A) $\pm 2$ kV (crit. A)
Surge	EN 61000-4-5	Ethernet ports Power ports I/O ports	$\pm 2$ kV (crit. B), shielded cab. $\pm 0,5$ kV (crit. B) $\pm 1$ kV, L to L (crit. A) $\pm 2$ kV, L to GND (crit. A)
RF conducted	EN 61000-4-6	All ports	10 V/m (crit. A) (0,15 – 80 MHz)
Radiated emission	EN 55022	Enclosure	Class B
Conducted emission	EN 55022	DC power ports Ethernet ports	Class B Class B
Power frequency magnetic field	EN 61000-4-8	Enclosure	160 A/m (crit. A)
Dry heat	EN 60068-2-2	+75 °C *, 40 % rel. humidity	
Cold	EN 60068-2-1	-40 °C *	
Vibration	EN 60068-2-64 ed. 2	Vibration spectrum A.3 (rolling stock)	Category 1 (3 axis, 8 hours per axis)
Shock	EN 60068-2-27 ed. 2	half-sine, 50 g peak, 11 ms	

Table 22: Type tests and environmental conditions

\* The temperatures given are for the basic version of the router. These can vary for other versions.



## 4.4 Technical parameters of WiFi

WiFi	
Antenna connector	R-SMA – 50 Ω
Supported WiFi band	2.4 GHz, 5 Ghz
Standards	802.11a, 802.11b, 802.11g, 802.11n
2.4 GHz supported channels	1, 2, 3, 4, 5, 6, 7, 8, 9, 10, 11, 12, 13
5 GHz supported channels <sup>1</sup>	36, 38, 40, 42, 44, 46, 48, 52, 56, 60, 64, 100, 104, 108, 112, 116, 120, 124, 128, 132, 136, 140, 149, 153, 157, 161, 165
Type of device	Access point, station
Max. clients in AP mode	10
WiFi TX Output Power	17,3 dBm
WiFi RX Sensitivity	-96,3 dBm
AP maximum users	10 users (WiFi module supports multi-role operation in STA and AP. Multi-role does not affect the maximum number of users).

Table 23: Technical parameters of WiFi

## 4.5 Technical parameters of I/O port

- Characteristics of inputs:

Logical 0 / 1*	Voltage	Current	Web interface status
log. 1 max	3 V	0.4 mA	Off
log. 0 min	5 V	0.7 mA	On
log. 0 type	12 V	2 mA	On
log. 0 max	60 V	7 mA	On

Table 24: Characteristics of inputs

\* The binary input status in the Shell is returned via `io get bin0` or `io get bin1`.

- Binary output parameters:
  - 60 V AC / 300 mA
  - 60 V DC / 300 mA

<sup>1</sup>Supported channels depends on selected Country Code.

## 4.6 Technical Parameters of Power over Ethernet (PoE)

Standards IEEE 802.3at-2009 (PoE+) and IEEE 802.3af-2003 (PoE) are supported. Cabling needed is Category 5, up to 12.5  $\Omega$ . It is possible to use a passive PoE injector.

PoE PD: parameters for opposite PSE	
Input voltage range	42.5 – 57 V
Power available	25.50 W
Maximum current	600 mA

Table 25: PoE PD: parameters for opposite PSE

PoE PSE parameters	
Power supply needed	44 – 57 V, 65 W
Power available	2x 25.50 W (ETH0, ETH1)

Table 26: PoE PSE parameters

## 4.7 Other Technical Parameters

Parameter	Description
CPU power	2 DMIPS per MHz
Flash memory	256 MB
RAM	512 MB
M-RAM	128 kB

Table 27: Other technical parameters

# Appendix A: Troubleshooting

If you cannot connect to the router from your PC, your network card may be configured in such a way that it is not possible to connect to the router. Take one or more of the following steps in order to solve the problem:

- Make sure your PC's network card is configured to obtain the IP address from the DHCP server (by default the DHCP server is running in the router).
- Connect the router to the PC via Switch.
- Connect the router to the PC, start the router first and then start the PC after the router's initialization.

## Ethernet connection fails or is not establishing.

- It is possible to turn auto negotiation off and set a rate and duplex manually on the Ethernet interface of the router. Available on "LAN Configuration" page in the router.

## Mobile WAN connection fails.

- Check the signal power ("Mobile WAN status" page). If the signal power is weak, you will have to use a better antenna. If the neighbouring cells have a similar signal strength, you will need to use a directional antenna. For proper operation, the signal levels have to be good.
- Try to enable automatic ping from the router, which will check the connection when there are no data running and in the case of a failed ping, restart the connection. This can be done on the "Mobile WAN Configuration" page in the router in the "Check connection" section. "Enable + bind" option is to ensure the ping goes always through Mobile WAN network interface.

## Mobile WAN connection cannot be established.

- Check the "Mobile WAN Configuration" – APN, name, password and IP address (all can be blank).
- Try to enter the SIM card PIN – verify that the SIM card has the PIN code entered. Available on "Unlock SIM Card" page in the "Administration" section.
- In a private APN it is not recommended to get the DNS settings from operator (on "Mobile WAN" page)
- Go to "System Log" page in "Status" section and observe where the error occurs.

## I cannot connect from the Internet to the device behind the router. I have NAT enabled.

- The device's gateway has to be configured so it points to the router.

## I can't access my Web server placed behind the router over NAT.

- The remote HTTP access to the router has to be disabled on "NAT Configuration" page in the router. Also enable "Send all remaining incoming packets to default server" feature and fill in the IP address of your Web server. On the Web server, the default gateway has to be the IP address of the router.

## DynDNS doesn't work.

- With private APN this will not work.

- If the same IP address is recorded in your canonic name as a dynamically assigned address, it means that the operator is using NAT or a firewall.
- You can verify NAT using ping to your server with static address and then compare with router's IP address.
- You can verify a Firewall by accessing remotely to the router's Web interface.
- The operator may not provide the address of DNS server and without DNS server's address it is impossible to connect to the dyndns.org server. The following messages will be shown in the System Log:
  - DynDNS daemon started
  - Error resolving hostname: no such file or directory
  - Connect to DynDNS server failed

 **L2TP or IPSec isn't establishing.**

- Check the "System Log" page for error messages.

 **IPSec tunnel establishes but the communication does not run.**

- Probably there are bad routing rules defined in the connected devices, or the default gateway.

 **I switched the router to offline mode by SMS message, but the router is in online mode after reboot.**

- SMS messages do not change the router configuration. They remain in effect only until the router is rebooted.

### **Serial communication is not working.**

- Verify that the router model supports serial communications. Also verify the serial communication settings. To do so, open the router's configuration menu via the web browser, select the appropriate "Expansion Port" from "Configuration" part of the menu and verify the settings.

### **Is the router Cisco compatible? Can I use the Cisco configuration?**

- No, the Firmware in the router (ICR-OS) is based on Linux with BusyBox. Thus the Cisco configuration cannot be used. But network connections are defined by standards so connecting the router to the Cisco or other networking devices is possible and will be compatible.

### **FTP or SFTP does not work**

- FTP will work on v2 routers only. You can use SFTP on all routers to transfer files to/from the router. If having troubles with FTP on v2 routers, make sure you have FTP enabled: "Configuration" section, "Services", "FTP". Then you can connect with any client on port 21 with name and password same as for the Web interface. If having troubles with SFTP, make sure you have SSH enabled: "Configuration" section, "Services", "SSH". Then you can connect with any client on port 22 with name and password same as for the Web interface.

### **How can I connect to the router's command line? (SSH, Telnet)**

- You can use SSH on all routers or Telnet on v2 routers only. SSH is enabled by default, but you can verify in Web interface in "Configuration" section, "Services", "SSH". Then connect with any SSH client on port 22 of the router. User and password is the same as for the Web interface. Telnet on v2 routers can be enabled here: "Configuration" section, "Services", "Telnet".

# Appendix B: Customer Support

## Customer Support for Europe

### Advantech Czech s.r.o.

Sokolska 71  
562 04, Usti nad Orlici  
Czech Republic

Phone: +353 91 792444  
Fax: +353 91 792445  
E-mail: [iiotcustomerservice@advantech.eu](mailto:iiotcustomerservice@advantech.eu)  
Web: [www.advantech.com](http://www.advantech.com)

## Customer Support for NAM

### Advantech B+B SmartWorx

707 Dayton Road  
Ottawa, IL 61350 USA

Phone: +1-800-346-3119 (Monday – Friday, 7 a.m. to 5:30 p.m. CST)  
Fax: +1-815-433-5109  
E-mail: [support.iiot.ana@advantech.com](mailto:support.iiot.ana@advantech.com)  
Web: [www.advantech.com](http://www.advantech.com)

## Customer Support for Asia

Phone: +886-2-2792-7818 #1299 (Monday – Friday, 9 a.m. to 5:30 p.m. UTC+8)  
Fax: +886-2-2794-7327  
E-mail: [icg.support@advantech.com.tw](mailto:icg.support@advantech.com.tw)  
Web: [www.advantech.com](http://www.advantech.com)

# Appendix C: Regulatory & Safety Information

## Safety Notices



Please, observe the following instructions:

- The router must adhere to all relevant international and national laws, including any specific restrictions governing its use in designated applications and environments.
- To prevent potential injury and appliance damage, ensure compliance with regulations by using only authorized accessories. Unauthorized modifications or use of unapproved accessories could damage the router, violate regulations, and void the warranty.
- Do not attempt to open the router.
- Before handling the SIM card, turn off the router and disconnect it from the power supply.
- **Caution!** This equipment is not suitable for use in areas with children. Small children could swallow the SIM card.
- Ensure the power supply does not exceed 48 V DC maximum.
- Avoid exposing the router to extreme ambient conditions. Safeguard it against dust, moisture, and high temperatures.
- Only deploy routers with appropriate certification and labeling in environments containing flammable or explosive materials, such as gas stations, chemical plants, or areas involving explosives. Users must observe restrictions pertaining to radio device usage in such settings.
- When traveling by plane, switch off the router. Using it onboard could jeopardize flight operations, disrupt mobile networks, and potentially violate regulations. Non-compliance may result in telephone service suspension, cancellation, or legal repercussions.
- Exercise heightened caution when operating the router near personal medical devices like cardiac pacemakers or hearing aids.
- The router may cause interference when operated in close proximity to TV sets, radio receivers, or personal computers.
- It's advisable to create a suitable backup of all critical settings stored in the device's memory.



## Product Disposal Instructions

The WEEE (Waste Electrical and Electronic Equipment: 2012/19/EU) directive was introduced to ensure that electrical/electronic products are recycled using the best available recovery techniques to minimize the environmental impact. This product contains high quality materials and components which can be recycled. At the end of its life this product **MUST NOT** be mixed with other commercial waste for disposal. The device contains a battery. Remove the battery from the device before disposal. The battery in the device needs to be disposed of apart accordingly. Check the terms and conditions of your supplier for disposal information.

# Appendix D: Related Documents

[1] [Configuration Manual for SmartFlex Routers](#)



[EP] Product-related documents and applications can be obtained on **Engineering Portal** at <https://icr.advantech.com/download> address.





We, Advantech Czech s.r.o., declare that the radio equipment narrated in this user's manual complies with Radio Equipment Regulations 2017 (**S.I. 2017 No. 1206**).



We, Advantech Czech s.r.o., declare that the radio equipment narrated in this user's manual complies with Directive **2014/53/EU**.

The full text of the EU Declaration of Conformity is available at the following internet address:  
[icr.advantech.com/eudoc](http://icr.advantech.com/eudoc)